

HSF RoHS

SPECIFICATIONS PERFORMANCE

Electical Rating:AC/DC 50V 0.5A
 Insulation Resistance: 500MΩ
 Contact Resistance:50mΩ Max
 Withstang Volt:150V AC/minute
 Opratng Temperature:-40°to+105°
 Material
 Contact:Phosphor Bronze GOLD-Plated
 Housing:PA46
 Max.Processing Temp:230°C for 30-60 seconds
 (260°C for 10 seconds)

NO. OF Contacts	Dimensions	
	A	B
20pin	7.20	4.50
30pin	9.70	7.00
32pin	10.20	7.50
36pin	11.20	8.50
40pin	12.20	9.50
50pin	14.70	12.00
60pin	17.20	14.50
80pin	22.20	19.50
100pin	27.20	24.50

Ordering Information

3720 F XXX 043 XX X X OX

F=Female M=Male No.of pins 20~100P Plastic Height 043=4.3mm Contact Plating G0:Gold Flash G1:3U" Gold G2:5U" Gold G3:10U" Gold G4:15U" Gold G5:30U" Gold S0:Gold Flash/Tin Insulator Material Option C=BK-PA6T D=BK-PA46 F=BK-LCP Packing T=Tube R=Reel code string 01~99

Recommended P.C.B Layout(Top Side) (PCB BOARD TOLERANCE±0.05)

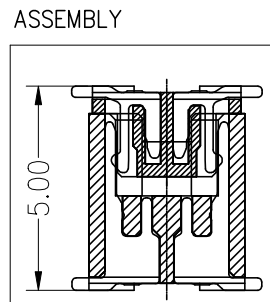
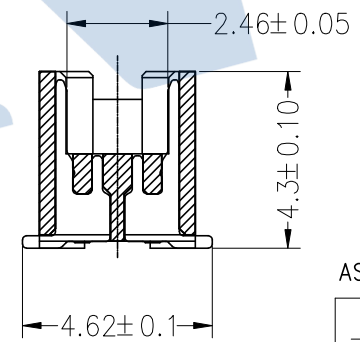
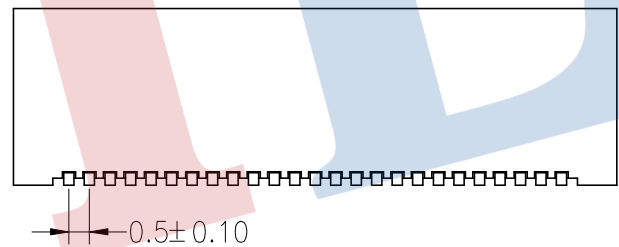
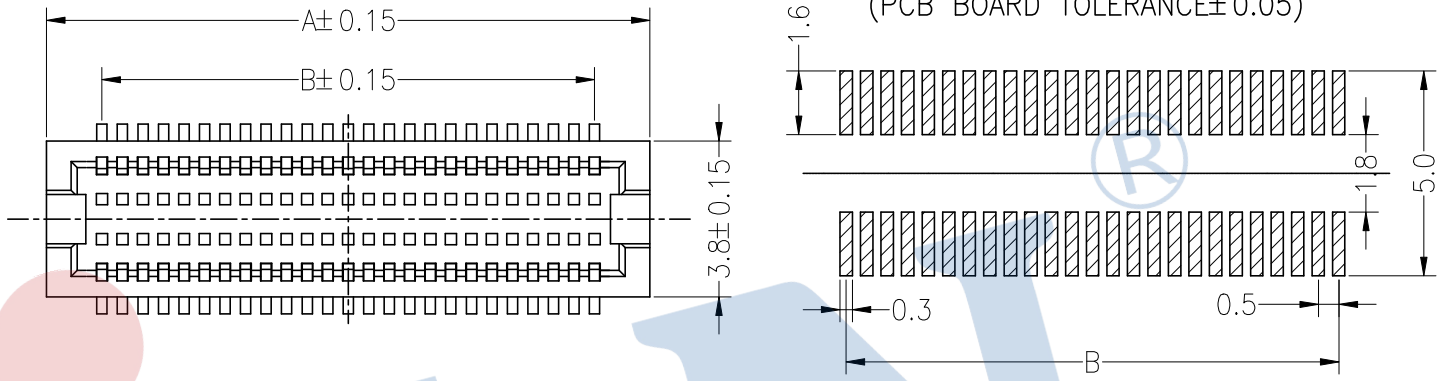

OPERATION	DRAW	Jelly Feng	22.06.30
X.X ±0.30	CHECK		
X.XX ±0.20			
X.XXX ±0.10			
Angle ±3°	APPROVE		
DIM TOL			

SCALE	FIT	JILN ® 深圳市锦凌电子有限公司 SHENZHEN JINLING ELECTRONICS CO.,LTD Tel: 86-755-2997-5806/5802 Fax: 86-755-2997-5992	
UNIT	mm		
SIZE	A4	PART NO.	3720FXX043XXXX0X
SHEET	1/1	TITLE:	0.5BTB NPin H4.3 Female
PROJ.	◆		

A0	2022.06.30	NEW DRAWING	
REV	DATE	MODIFICATION DESCRIPTION	CHANGE